

COFFEE GRINDER #01 BAR
Barista Edition

NEW!

1954
Barista Series



Internationally patented models

BARISTA EDITION

This special edition dedicated to baristas is based on the traditional coffee grinder from 1954. A unique design and high quality features for a premium coffee. It can grind small amounts of coffee thanks to its 1 kg (2.2 lbs) hopper, ideal for specialty coffee. It offers a precise micrometric setting for all types of filtrations: espresso, filter, French press...

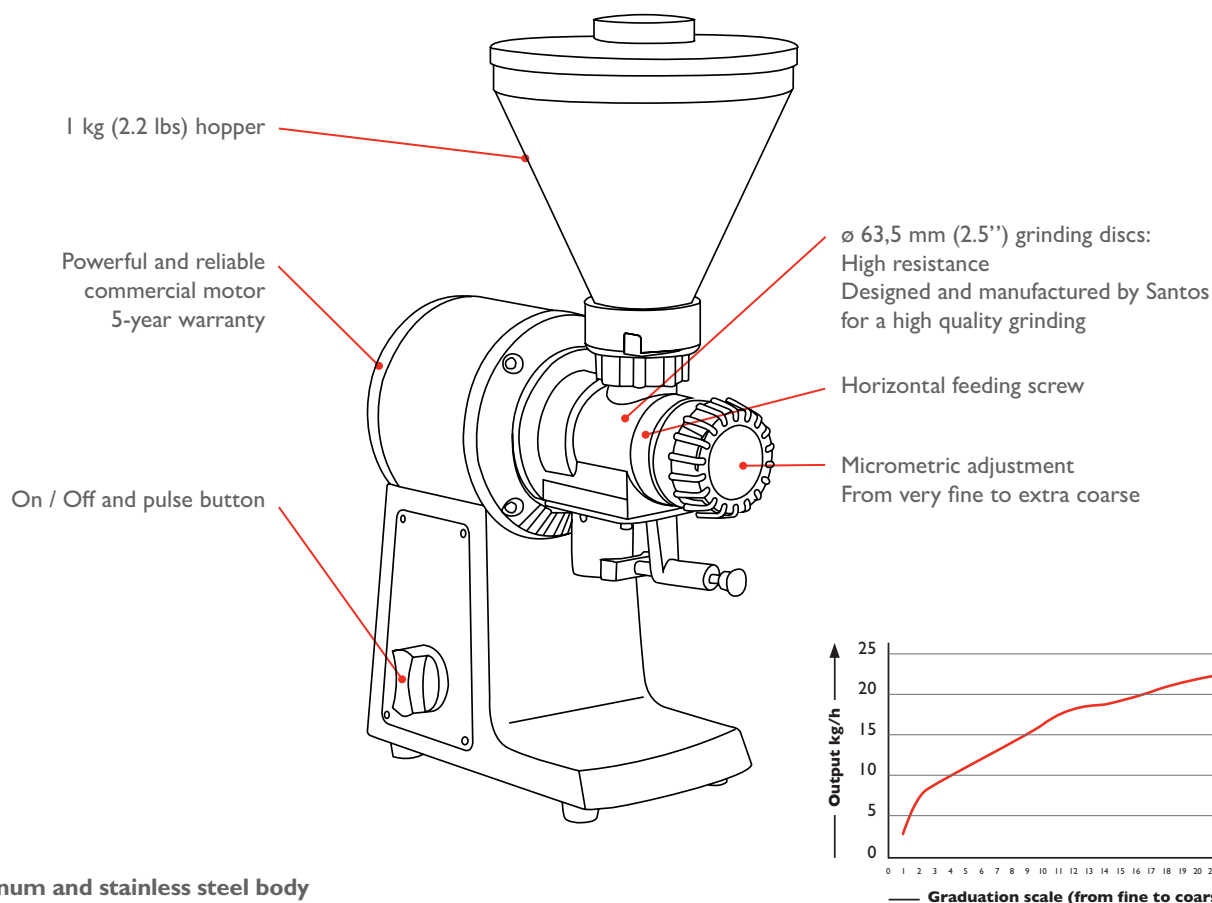

A FRENCH KNOW-HOW SINCE 1954

Santos manufactures high quality coffee grinders since 1954, as well as its own grinding discs for a perfect grinding.

Santos strengths :

- The quietest coffee grinders on the market
- A high quality unimodal grinding
- Constant portion dispensed
- Heat dissipation : No "burnt coffee" effect while grinding
- Anti-static system
- Robustness and high quality of the materials

1954 BARISTA SERIES

PRECISION AND QUALITY

www.santos.fr

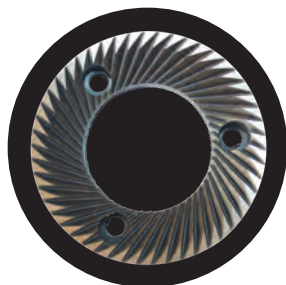

Exclusive santos ø 63,5 mm grinding discs

Santos manufactures its own grinding discs since 1954 to ensure a high quality grinding

—
Homogeneous and constant grinding



Direct dispensing of coffee

Ergonomic coffee grinder spout

—
No coffee retention



Micrometric adjustment

Precise micrometric scale to adjust the grinding size: espresso, filter, French press...

TECHNICAL SPECIFICATIONS



Motor

Single phase : 220-240 V – 50 / 60 Hz – 600 W – CE
100-120V – 50/60 Hz – 650W – CE

Speed : 1500 rpm (50 Hz)
1800 rpm (60 Hz)



Weight

Net : 14,5 kg (31 lbs)
Shipping : 15,5 kg (33 lbs)

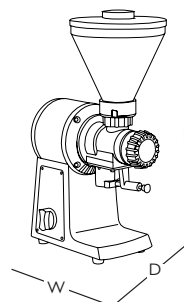

APPLIANCE

P : 330 mm (13")
L : 190 mm (7")
H : 560 mm (22")

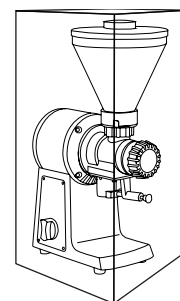

SHIPPING BOX

P : 410 mm (16")
L : 300 mm (10")
H : 575 mm (23")

SAFETY, STANDARDS, HYGIENE

In accordance with the following regulations

Machinery directive 2006/42/EC
Electromagnetic compatibility 2014/30/UE
"Low voltage" Directive 2014/35/UE
Regulation 1935/2004/EC (contact with food)
RoHS directive 2011/65/UE

Harmonized European Standards

EN ISO 12100 : 2010
EN 60204-1 + A1 : 2009
EN 60335-2-64 : 2004 Commercial electric kitchen machines
CE (European standards)

Thermal Safety

Motor protected by internal thermal detector

Acoustic Safety

Very silent and powerful asynchronous motor

Hygiene

All removable parts can be put in a dishwasher or easily cleaned with hot soapy water.

PRODUCT : 2-YEAR WARRANTY | MOTOR : 5-YEAR WARRANTY

COFFEE GRINDER #01 BAR



www.santos.fr

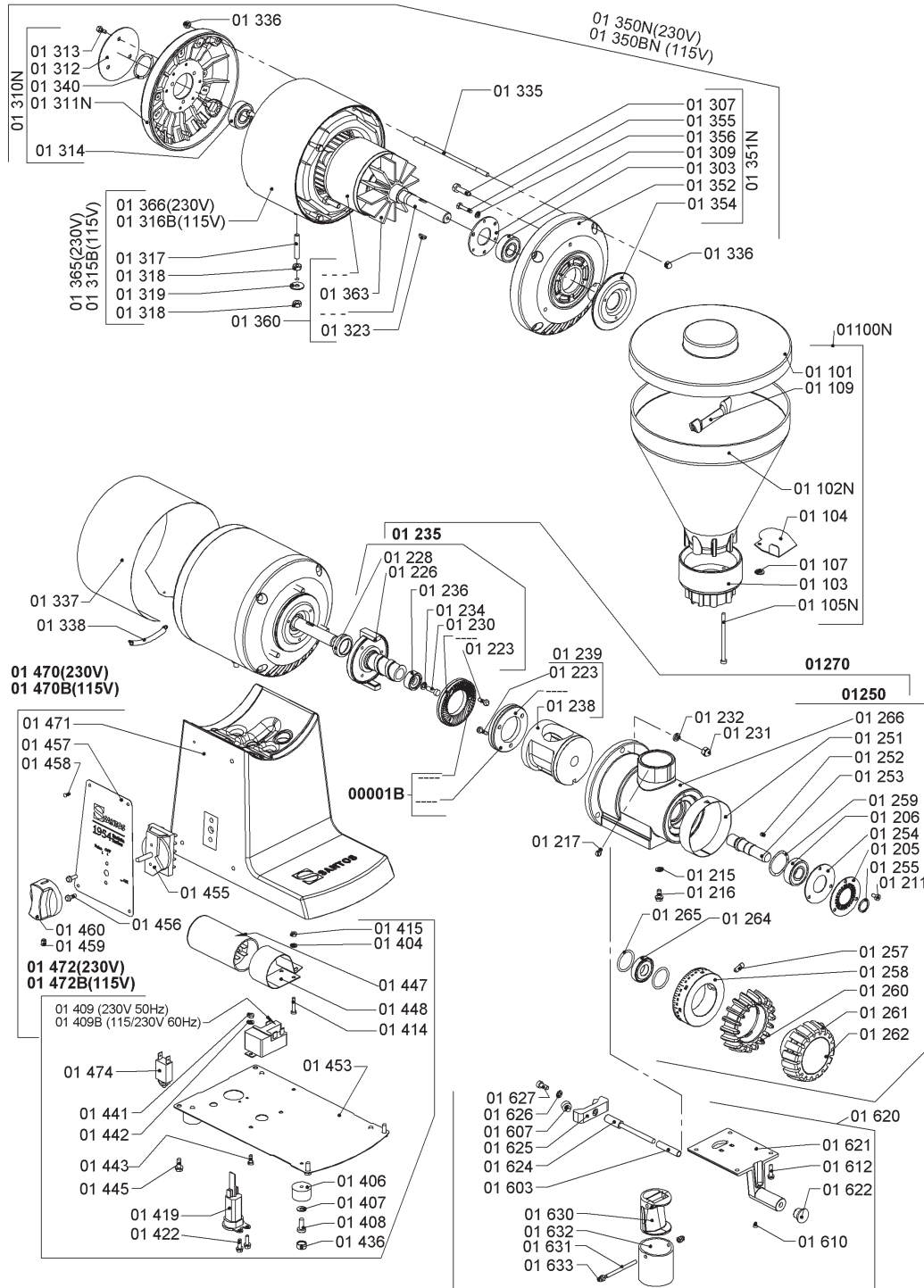

07/2019 - V2

SANTOS

140-150 Avenue Roger Salengro BP 80 067 – 69511 Vaulx-en-velin Cedex (Lyon) – FRANCE
 Tel. +33 4 72 37 35 29 – Fax. +33 4 78 26 58 21 – Website: www.santos.fr – Email: santos@santos.fr

Follow us on #SantosAddict social networks